

*In the simplest terms, we are trying to assemble a leak free line, or string, that will last longer than the field produces. To do that, each and every joint must be assembled with a uniformly loaded “hoop” or contact pressure, that exceeds the pressure of the fluid to be contained, between the contact surfaces of the tubes that are joined. This is done by “packing off” the space in the joint with, or without, “pre-stressing” the box (female) in hoop-wise tension, and the pin (male) in hoop-wise compression. Pipe dope is used to pack off and to uniformly distribute the contact pressure at the micro-scale level. In the process of doing this, we also achieve the mechanical assembly of pipe joints into a line, or tubing/casing string, for the conveyance of a fluid.*

**OUTLINE**

>

- The Nature of Fiberglass
- General Rules
- Threads
  - Non-sealing
  - Sealing
- Lubricant/Sealant
- Teflon® Tape
- Elastomeric Seals
- Torque Based Make-up
- Position Based Make-up
- Tools
- Special Cases
- Repairs
- New Lateral Tie-Ins
- Cold Weather Installation
- Specific Installation Procedures
  - CEN
  - SP/SP8/SPH
  - **Downhole Tubing**
- Service Guide



15LR-0007  
15HR-0003



**Important Note Limited Warranty**

*The information and recommendations contained in this literature regarding Centron® Fiberglass Products are based on currently available data and believed to be representative of the product under specific conditions. However, such factors as variations in environment, application or installation, changes in operating procedures, or extrapolation of data may cause different results. Centron International Inc. makes no representation or warranty, express or implied, including warranties of merchantability or fitness for purpose or service life, as to the accuracy, adequacy, or completeness of the recommendations or information contained herein. Centron International Inc. neither assumes nor authorizes any representative or other person to assume for it, any obligation or liability other than such as is expressly set forth. Centron International Inc. reserves the right to change any and all specifications or descriptions without notice.*

### The Nature of Fiberglass

Fiberglass pipe is a tough, high strength to weight ratio product but, unlike metals which are ductile, fiberglass is not as forgiving. When subjected to large impact, crushing, and/or bending forces, fiberglass pipe performance is adversely affected as the product could experience delamination and cracking. Therefore, fiberglass pipe must be handled with care in storing, transporting, and installing to prevent damage from external forces.

#### GENERAL RULES >

#### Some General Rules for Assembly of Fiberglass

1. Keeping all components clean during assembly is a prime key to success. It is impossible to get *uniform* contact pressure between threads if they are contaminated with foreign material.
2. If some is good, *more is not better*. Use force and materials in the quantities called for.
3. Inspect for damage every time the product is handled.

#### THREADS >

#### Non-sealing Threads

Threads are a helical ramp that provides a mechanical advantage allowing you to exert more force with less effort. In the case of Centron® CEN end connectors, there is no seal from the threads. Sealing is accomplished by compressing the O-ring. The threads serve to enable you to compress the O-ring without much effort and they hold the joint together in service.

#### Sealing Threads

By combining the helical ramp of threads with another ramp, in the form of an overall taper of the thread form, a double mechanical advantage is developed. Examples are Centron's SP/SPH, API 8rd and NPT threads. With torque, the wedging action of the threads against each other compresses the pin and stretches the box in the hoop-wise direction. The contact pressure developed between the mated threads exceeds the intended hydrostatic pressure of the fluid to be pumped, when the torque applied is sufficient.

#### LUBRICANT / SEALANT >

#### Thread Dope

All sealing threads are designed with a root to crest gap to assure that the load is carried on the flanks of the threads. This is to accommodate tolerances in both the thread height and lead. Because of the high contact pressure developed between the threads, a lubricant is required to prevent galling of the threads. A lube/sealant (dope) is used to both lubricate the threads and pack-off the space remaining between the root and crest of each thread. The dope for fiberglass usually contains particles of teflon and/or other polymers to accomplish the pack-off and to help distribute the force as equally as possible across the threads. Use only the dope recommended by the manufacturer, since the dope used has a powerful effect on the torque/contact pressure relationship.

#### Centron Approved Thread Dope:

- Lubon 404 and 404LT
- Jet Lube TF15 and TF15 Arctic Grade

**Teflon® Tape**

When properly applied, Teflon® tape enhances the performance and seal of interference threads by:

- cushioning the impact of the initial stabbing operation
- deforming under compression to both pack off small spaces and equally distribute force
- assuring that a film of slippery material is between the threads when high contact force is required for high pressure applications or when the material tends to gall easily (aromatic amine cured pipe and fittings that have large overhung loading problems)

When improperly applied, Teflon® tape can do more harm than good. The quality of Teflon® tape varies significantly among manufacturers, so choose tape that does not fray easily and has sufficient strength for tensioning during application. Instructions are based on the use of one inch wide tape. A good rule of thumb; use tape when the nominal diameter, in inches, times the pressure rating, in PSI, is 4000 or more and on all aromatic pipe and fittings

**ELASTOMERIC  
SEALS** >**Rubber O-rings**

Rubber compounds (elastomers) have the ability to take huge changes in shape and retain pressure resistance capability. A hoop is compressed in a confined space between the pipe ends such that fluid pressure is contained. Depending on the design used, the elastomer may be further compressed by fluid pressure against it. A thin, clean lubricant is required to facilitate compression of the seal without pinching or tearing the rubber. Any contaminant may cut or hold the rubber off of its seating surface and result in a leak. Dope must not be used on rubber seal elements, or their seating surfaces. Always inspect rubber seal elements carefully for cuts and nicks before assembly. In an effort to help prevent O-ring damage, Centron® does not ship pipe with O-rings installed.

**Centron Approved Seal Lubricants:**

- Silicone grease
- Motor oil

**TORQUE BASED MAKE-UP** > Torque (ft lbs) is defined as the perpendicular force (lbs) applied to the wrench handle times the distance (ft) from the pipe centerline to the point at which the force is applied. The use of body weight is an acceptable way to determine force.

The torque requirement for each size product is given in terms of a range. This means that torque will fall into the low end of the range for low pressure products and the high end of the range for high pressure products.

For **SP8, DH8** and **DHC8** (8 RD EUE and LTC) connections, torque is the controlling factor for make-up. Position can be used as a reference indicator of proper make-up. Specific instructions for **Torque Based Make-up** are detailed later in this guide.

**POSITION BASED MAKE-UP** > For **CEN, SP, SPH, DH** and **DHC** connections, the position of the box and pin relative to each other is the controlling factor for make-up. Torque should be used as a reference indicator of proper make-up. Specific instructions for **Position Based Make-up** for each series of pipe and tubing are detailed later in this guide.

**TOOLS** > Use of common strap wrenches, pipe wrenches, chain tongs, etc., on Centron products is acceptable. Band wrenches designed specifically for Centron pipe are available on order from Centron International Inc..

Other tools that are used such as floats, pipe jacks, rollers and supports should be made of or padded with wood, rubber, or plastic. Do not use chain for tie down or lifting slings; use nylon straps or rope. For downhole operations, slips should be clean and sharp and fit the build-up or pipe body. Slip type elevators or a Centron-supplied lift pin are required. Rig tongs may be used for break-out if they fit well but they should only be used to loosen the joint; disengage by hand so as not to grind the threads on each other.

**SPECIAL CASES** > **Fittings**  
Elbows and tees are necessarily made-up to an orientation. Because the box is thick on fittings, you may expect that the torque level required will be toward the high end of the range specified. With Centron fittings, you may exceed the maximum torque level for pipe by a factor of 1.25, to get a fitting to “look” the right way. If additional rotation is required go back to the joints previously laid and get a little bit of rotation from each joint.

**REPAIRS**

- > Centron pipe is made in exact lengths, with a few rare exceptions when the male thread is reworked. For repairs we supply a flanged repair joint that is of the same exact length. To make a repair, simply cut the damaged joint in two, unscrew the two ends and screw in the flanged sections. You may find that there is a small difference in length due to the difference in installation and service temperatures and/or mechanical shock on the line due to the failure. If the repair joint is too short, it is permissible to jack the line together, with the flange studs, up to 1 inch per joint of pipe exposed. If the length gap is greater than that, either uncover more pipe so it is free to stretch, or put in a filler ring and extra gasket between flanges. If the repair joint is too long, simply 'snake' the pipe, being sure to uncover enough so as not to exceed the minimum allowed bending radius for the product involved.

**NEW LATERAL  
TIE-INS**

- > For new tie-ins, we supply a flanged and teed joint of the same exact length. The procedure for installation is essentially the same as for a repair, but obviously requires the assembly of the tee and lateral connections.

We also supply all of the materials to do repairs and tie-ins with bonded parts in most sizes and pressures, but we prefer the all-mechanical approach because it is not sensitive to weather conditions and does not require the use of a taper tool, adhesive and heat packs.



**COLD WEATHER >  
INSTALLATION  
below 10° F (-12°C)**

1. Thread Cleaning - If there is ice on the pin or box threads, it must be removed. A light ice coating can be removed with a wire brush. Heavy ice is more easily removed using a torch\*, but care is required to assure that the thread surfaces are not scorched. The threads must be clean and dry before assembly.
2. Application of thread dope (order arctic grade for cold weather conditions) - The thread dope should be kept warm. The coating of dope must be thin (as if the threads were painted). The thread profile should be clearly visible with the dope in-place. If the ends of the pipe are warmed\* with a torch, or other means, to help ease the application of dope, allow both the pin and box to come to equal temperature before attempting to assemble.

It is extremely difficult to apply dope to threads when Teflon tape is required, when all components are very cold. The high viscosity of the dope and stiffness of the brush required for a thin coat will often tear the tape. For products that require Teflon tape (amine cured products and higher pressure rated products), it is essential that all components be warmed up\* for application of thread dope and Teflon tape.

3. For Centron products with O-rings, it is essential that the O-ring be checked for flexibility just prior to joint assembly. If the O-ring will not stretch, it must be warmed up until it will. It is a good idea, if cold conditions are anticipated, to keep them warm until just prior to joint assembly. Do not use a torch to warm the O-rings.

*\*Note: When using a torch to warm the pin and box keep the flame moving constantly. Monitor temperature with the bare hand and stop heating when pipe ends are uniformly warm to the touch.*



*Centron® CEN series pipe is designed for simple and easy installation, without the use of special tools or adhesives. The following guidelines are presented to aid the user in obtaining maximum reliability and performance of this product in demanding oilfield, mineral extraction, and other fluid handling applications.*

**I. DITCH  
PREPARATION**

1. Ditch should be deep enough to meet requirements of each particular installation.
2. If soil is rocky, ditch should be dug deeper (6" minimum) and filled back to the proper level with sand or good soil for bedding.
3. When bends in the ditch are necessary, consult pipe literature for minimum allowable bend radius of pipe.
4. Pipe should be run through conduit at road crossings. Conduit should be sitting on virgin soil. Use centralizers or pad the pipe at intervals (specified in catalog spans) with protective covering inside conduit. Fiberglass pipe is pushed through the casing and joined. Linkseals are recommended to reduce any shearing tendencies at conduit ends. Sandbag fiberglass as it exits the conduit at each end (see figure 1). Conduit for 6", 8" and 10" low pressure pipe must be vented to atmosphere.
5. The ditch should be cut wider to facilitate in-the-ditch assembly in the area of the crossings.

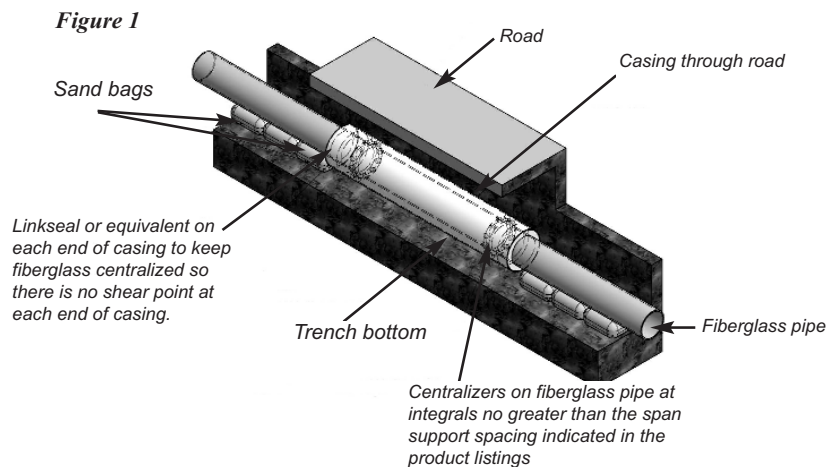

**II. PIPE  
INSTALLATION**

**A. GENERAL**

1. String the pipe along the side of the ditch opposite the excavated soil with the pin end pointing in the direction of flow.
2. Each joint should be checked visually for shipping and/or handling damage. Shallow scratches and abrasions are generally insignificant but if the pipe has cuts into the laminate, bruises or fractures it should be set aside for disposition.
3. If required, install fiberglass to steel crossovers using Centron approved thread dope. Coat both steel and fiberglass threads lightly, screw together, and torque to values in Table One.

**B. CEN MAKE-UP PROCEDURE**

1. After removal of end protectors, check box and pin threads for damage or contamination. Remove any contamination by wiping with clean paper towels. Use a fine wire brush or rags to remove ice or dried soil.
2. Apply a light coat of seal lubricant (not thread dope) to the box threads and O-ring seal area, pin threads and O-ring groove.
3. Install O-ring into the O-ring groove on the pin. Be careful not to damage the O-ring. Apply seal lubricant to O-ring.
4. Makeup can best be accomplished with one person on each end of the pipe and one person near the middle of the joint being installed.
5. One person should align the box and pin to slip together making sure that the O-ring is not crimped or displaced during initial engagement.
6. The person in the middle of the pipe should begin rotation to the right and visually align and “feel” the alignment of the two joints as he screws them together. Rotation should be very smooth if proper alignment is maintained. When the O-ring begins to seat, additional rotational force will be required. At this point the person on each end should help in making up the pipe as far as possible by hand. Pipe will normally make-up to one turn past the white band, or to shoulder, but must always be made-up far enough to cover the white band. If the connection cannot be fully made-up by hand, strap wrenches may be used to complete the make-up. If the connection makes-up to the shoulder using strap wrenches no torque should be applied after shouldering. Use wrenches only on the upset area of the pin and on the last 3 inches of the box. **Never use wrenches on the pipe wall.**
7. The connection may be backed off up to one full turn from shoulder position, or back to the white line without loss of seal if required for fitting orientation.
8. Should a joint be difficult to make-up properly, it should be separated, cleaned, relubricated and the procedure repeated. If difficulty still occurs, it should be set aside for disposition.
9. If the pipe is made-up on the side of the ditch take care not to exceed the minimum allowable bend radius of the pipe when lowering the pipe into the ditch.
10. Some rubber compounds lose elasticity at low (<10°F) temperatures and may not seal. Before installing at low temperatures contact Centron or refer to the section on low temperature installation in this guide.

**III. PRESSURE  
TESTING**

1. Hydrostatic testing can be potentially dangerous. Adequate safety precautions should always be taken to prevent damage or injury during testing.
2. Testing with air or gas is not recommended because of the potential danger of compressed gas.
3. An initial test should be performed in the open ditch prior to backfilling. This test requires covering of the pipe to the top of the ditch only in areas of elbows and tees for a distance of 20 feet in all directions from the fittings. *See section on backfilling prior to starting any burial of pipe.* The fittings should be left uncovered for inspection. Covering the rest of the pipe is not required, although plugs of backfill should be applied along bends and may be applied at intervals along the pipe for added restraint if desired. Leave

all connections open for inspection. **If this test is not performed, Centron will not be responsible for any costs involved in finding the leak in the line after the line has been backfilled.**

4. When filling the line with water, when practicable, a soft pig should be run ahead of the water to remove the air in the line.
5. The rate of pressurization of the line should not exceed 200 psi per minute.
6. During the open ditch test, the line may be pressured up to, but not exceeding, the pipe's static pressure rating for a duration of not more than four (4) hours. During this test the line should be visually checked and monitored with a pressure gage or chart recorder.
7. Upon initial pressurization of the line some changes in gage pressure may be expected from air trapped in the line, and until temperature stabilization occurs. During the open ditch test, the line must be carefully monitored to prevent pressure increases due to temperature rise. Measures must also be taken in cold weather to prevent freezing of the test water.
8. After satisfactory completion of the open ditch test, the line should be backfilled as soon as possible.
9. During installation, open ditch testing should be performed at maximum intervals of 5000 feet. After completing each test, the section of line should be backfilled before installing and testing the next increment of pipe in the same installation.
10. A final test, after line has been completely backfilled, may be conducted as required by the customer. Maximum recommended test pressure is 100% of the static pressure rating of the pipe. However, it is allowable, at final test, to pressure the line up to 125% of the static pressure rating of the pipe if necessary to meet licensing requirements. Maximum test duration is 24 hours.

#### IV. BACKFILLING >

1. After testing has been completed, ditch should be backfilled as soon as possible to prevent possible damage to the line from falling rock, flooding, and other hazards.
2. The first six inches minimum depth of backfill should be good soil, free of sharp rocks, heavy boulders, and frozen clods of dirt. This cover of good soil provides even support for the pipe and protects it from damage as the rest of the ditch is backfilled with perhaps less desirable material.

*Centron® Surface Pipe is designed for simple and easy installation, without the use of special tools or adhesives. The following guidelines are presented to aid the user in obtaining maximum reliability and performance of this product in demanding oil field, mineral extraction and other fluid handling applications. For insertion applications see Section 10 of the Centron Engineering Manual.*

**I. DITCH >  
PREPARATION**

1. Ditch preparation and backfilling instructions in this guide are intentionally brief. For soft soil conditions consult Centron’s Engineering and Design Manual or Centron engineering.
2. Ditch should be deep enough to meet requirements of each particular installation.
3. If soil is rocky, ditch should be dug deeper (6” minimum) and filled back to the proper level with sand or good soil for bedding. In rocky soil, thin wall pipe should be rock shielded and all pipe must be covered at least six (6) inches with sand or fine soil.
4. When bends in the ditch are necessary, consult pipe literature for minimum allowable bend radius of pipe.
5. Pipe should be run through conduit at road crossings. Conduit should be sitting on virgin soil. Use centralizers or pad the pipe at intervals (specified in catalog spans) with protective covering inside conduit. Fiberglass pipe is pushed through the casing and joined. Linkseals are recommended to reduce any shearing tendencies at conduit ends. Sandbag fiberglass as it exits the conduit at each end (see figure 1). Conduit for 6”, 8” and 10” low pressure pipe must be vented to atmosphere.
6. The ditch should be cut wider to facilitate in-the-ditch assembly in the area of the crossings.

*Figure 1*

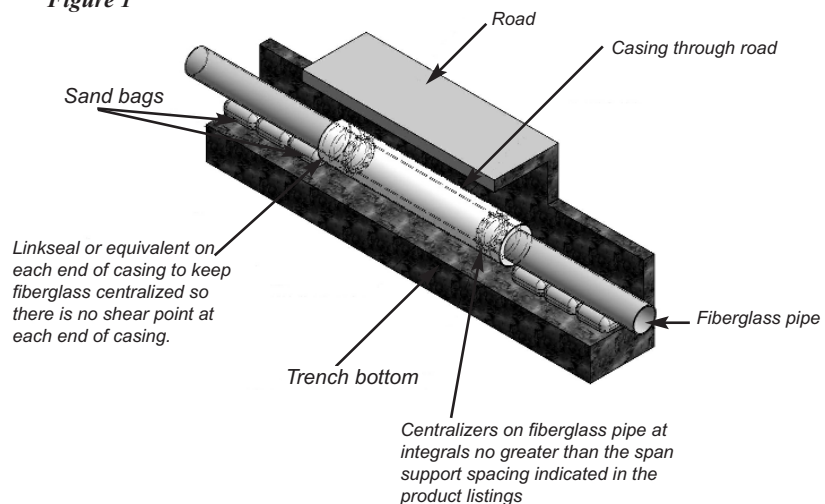

## II. PIPE > INSTALLATION

### A. SP/SPH CONNECTION

1. String the pipe along the side of the ditch opposite the excavated soil with the pin end pointing in the direction of flow.
2. If required, install fiberglass to steel crossovers using thread dope. Coat both steel and fiberglass threads lightly, screw together and torque to values in Table One. Use only fiberglass pins in steel boxes.
3. As each joint is handled it should be checked visually for shipping and/or handling damage. Shallow scratches and abrasions are generally insignificant but if the pipe has cuts into laminate, bruises (light colored areas indicating delamination) or fractures it should be set aside for disposition.
4. After removal of end protectors, check box and pin threads for damage.
5. Check box and pin for contamination. Remove any contamination by wiping with clean cloths or paper towels. Use a fine wire brush for the removal of ice or dried, hard soil contamination. Be sure that O-ring groove is clear of debris.
6. For standard make-up of Anhydride cured pipe apply a light, even coat of thread dope to the pin threads only. Do not allow any thread dope in the O-ring groove. A light coat of thread dope will effect a seal at the threads.
7. The combination of Teflon tape and thread dope provides optimum sealing capability for Centron surface pipe connections. This combination is recommended for high pressure applications, for all gas service (natural gas, CO<sub>2</sub>, etc.) and must be used on all Centron Amine cured pipe. Following is the recommended procedure for using Teflon tape and thread dope:
  8. Using 1" wide Teflon tape and starting from the small end of the threads, wrap the threads with the tape, advancing one thread pitch per revolution in a clockwise direction when facing pin end of the pipe. Apply a very light even coat of thread dope over the tape wrapped threads. Do not allow any tape or dope in the O-ring groove.
  9. Apply a light coat of seal lubricant to the O-ring groove. Install O-ring into the groove on the pin. Be careful not to damage the O-ring. Apply seal lubricant to the O-ring.
10. Thread dope should not be applied to the box (female) thread but a light coat of seal lubricant should be applied to the o-ring seating area (first 1 inch past the female threads).
11. Align the two joints to be connected and stab the connection by hand being careful to center the box and pin so that the O-ring and threads are not damaged upon initial engagement. If the pipe is too heavy to hold and stab by hand, then a side-boom with nylon strap should be used to support/lift the pipe (in the middle) during the stabbing and rotating operations. Do not use chains for lifting slings. A pipe stand or jack should be used for support and assistance in alignment if the pipe is light enough to lift by hand. **Proper alignment of the two joints during complete make-up is critical.** After proper visual alignment, make-up the connection by hand as far as possible. Rotation should be very smooth if proper alignment is maintained. Also listen for rubbing or grinding noises and, if present, recheck alignment before additional rotation. After hand tight make-up, apply wrenches and make-up as indicated below.

12. On the Box end, wrenches shall be used within the last 3 inches of the box. For the Pin end, wrenches are to be applied only on the upset area of the pin. Do not use pipe or chain wrenches on the body of the pipe. Standard pipe wrenches, chain tongs or Centron torque wrenches are acceptable to use. Select wrenches that fit well and maximize contact area with the pipe. The use of ADTECH Installer or Weatherford tongs should be considered for the installation of pipe 6 in. or greater.
13. Make up the connection per the following: **at minimum make-up position**, the box edge to pin shoulder distance (standoff) must be no more than .25 in. (6.3mm). **At maximum make-up position**, the connection assembly must always stop before the box edge contacts the pin shoulder. **Do not shoulder out the connection**. Use torque values in Table Two as a reference to monitor make-up.
14. Assemble connections to maximum make up position as long as maximum reference torque is not exceeded. If a connection does not make-up to the .25 in. (6.3 mm) maximum standoff distance at maximum reference torque, it should be disassembled, cleaned, and examined for contamination or galling of the threads. If no problem is found repeat the make-up procedure and if the problem persists, set the joint aside for disposition.
15. If pipe is assembled on the side of the ditch, take care not to exceed the minimum allowable bend radius of the pipe as it is lowered into the ditch. Care should be taken to minimize voids under the pipe after it has been placed in the ditch as this could provide insufficient support and promote the potential for excessive localized bending or shearing. Misalignment of connections at transitions from Centron pipe to steel flanged-connections must be avoided so as not to induce added stress to the Centron flange.
16. Pipe supports should be employed on each side of all fiberglass to steel connections (flanged or threaded) to maintain proper alignment if settling should occur, reference figures 4 and 5.
17. Some O-ring compounds lose elasticity at low (<10 °F) temperatures and may not be suitable for installation at low temperatures. Before installing at low temperatures, contact Centron International Inc. or refer to the section on cold weather installation in the Centron product catalog.

**B. 8RD EUE LONG THREAD FORM AND LTC CONNECTION**

1. String the pipe along the side of the ditch opposite the excavated soil with the pin end pointing in the direction of flow.
2. As each joint is handled it should be checked visually for shipping and/or handling damage. Shallow scratches and abrasions are generally insignificant but if the pipe has cuts into the laminate or bruises and fractures it should be set aside for disposition.
3. After removal of end protectors, check box and pin threads for damage and/or contamination. Remove any contamination by wiping with clean cloths or paper towels. It is extremely important that all threads are clean. Use a fine wire brush for removal of ice or dried, hard soil.
4. In making connections to steel use only fiberglass pins in steel boxes. Fiberglass SP8 pins are of the long thread form and must be cut off by the amount shown in Table Three before make-up into short, steel thread boxes. After this is accomplished clean threads, apply thread dope to both pin & box threads and make-up to torque shown in Table One. For cold weather installation, also see Table Four.
5. For fiberglass to fiberglass connections use 1" wide Teflon tape and starting from the big end of the threads, wrap the threads with the tape advancing 1/2" per revolution (4 threads) in a clockwise direction when facing the pin end of the pipe, dwell 1 revolution at the small end, then wrap the tape back to the big end advancing at 1/2" per revolution (4 threads). Apply a light, uniform coat of thread dope to the tape and to the box threads. The use of teflon tape is optional for sizes 2" through 4" at pressures of 800 PSI and below. However, the use of the tape will improve make up and seal characteristics.
6. Before stabbing, inspect the bore of the pipe that is to be turned and be sure that no sand, dirt, or debris will roll down the pipe into the threads during make-up. Stab the connection by hand, being careful to center the box and pin so that threads are not damaged upon initial engagement. ***Proper alignment of the two joints during complete makeup is critical.*** After initial alignment and stabbing, make-up the joint by hand as far as possible. Rotation should be very smooth if proper alignment is maintained. After handtight make-up, apply wrenches and make-up to torque values shown in Table Three. Wrenches must be applied only on the pin build up and within 3 inches of the box edge. Select wrenches that fit well and maximize contact area with the pipe. ***Never apply wrenches to the pipe body.*** As a visual check during make-up to torque, the box edge should range from allowing the last two (2) pin threads to show to stopping flush with the last pin thread. ***Do not make-up past the flush position regardless of torque.*** Do not exceed published torque ratings to achieve the minimum expected 2-thread make-up position. If maximum torque is obtained prior to the 2-thread make-up, disassemble and inspect threads for damage and/or contamination. Re-clean and try again. If still unable to achieve make-up, contact Centron and/or set aside for disposition.

**RISERS ( All joint types)**

1. Figures 2 and 3 show various methods of securing Fiberglass risers. Methods vary according to soil and loading conditions.

*Figure 2*

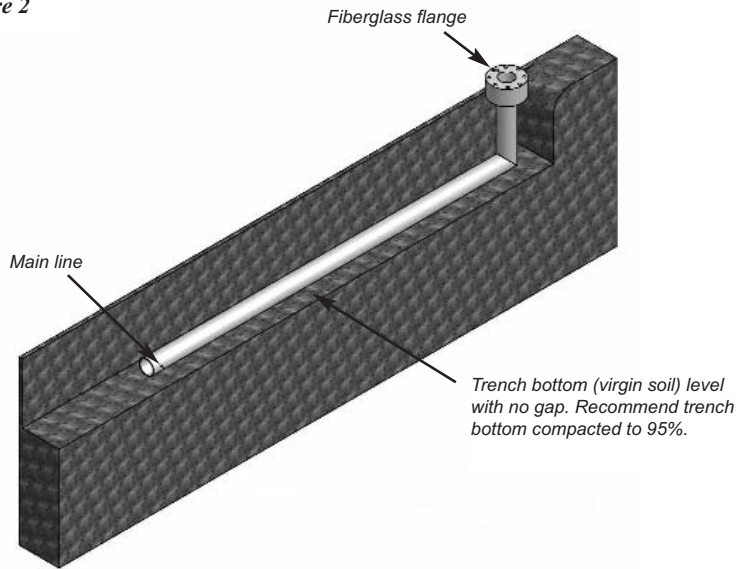

No bend for a minimum of 1 joint of fiberglass leading into the riser.

*Figure 3*

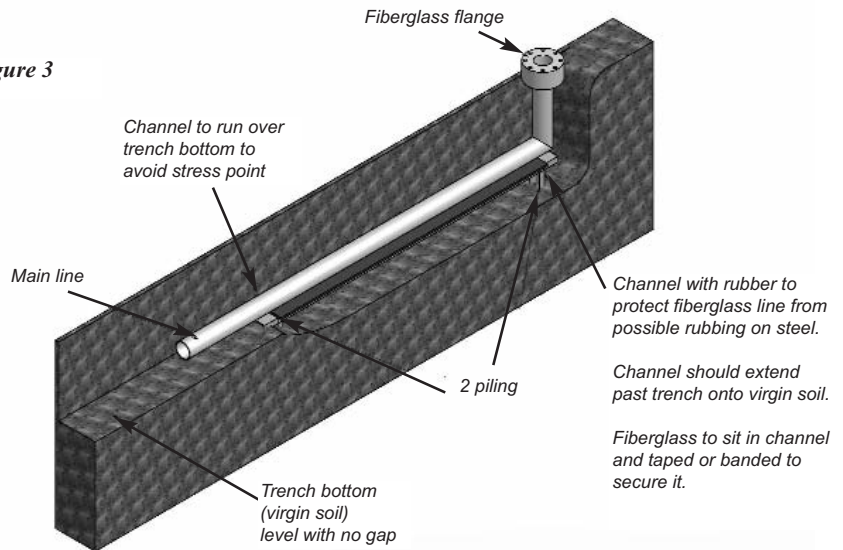

2. For attachment of fiberglass to Steel Risers make sure Steel Riser is supported.
3. Bring Fiberglass line in straight and make sure Fiberglass Flange is square with Steel Flange. Where Fiberglass Flange meets the Steel Flange, the Fiberglass Pipe should be sitting on virgin soil. Figures 4 and 5 show Steel Riser configurations.

*Figure 4*

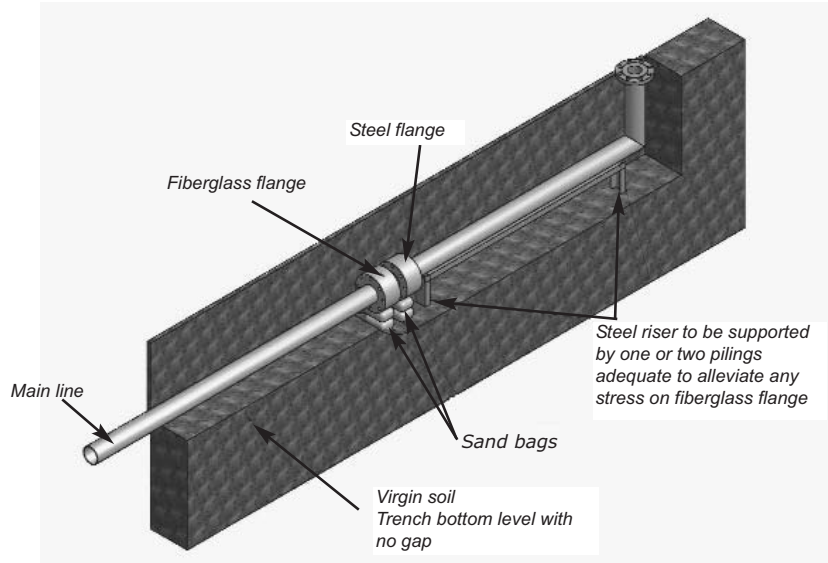

Flanges must be square and level before they are tightened.

No bend for a minimum of 3 joints of fiberglass leading into the steel connection.

*Figure 5*

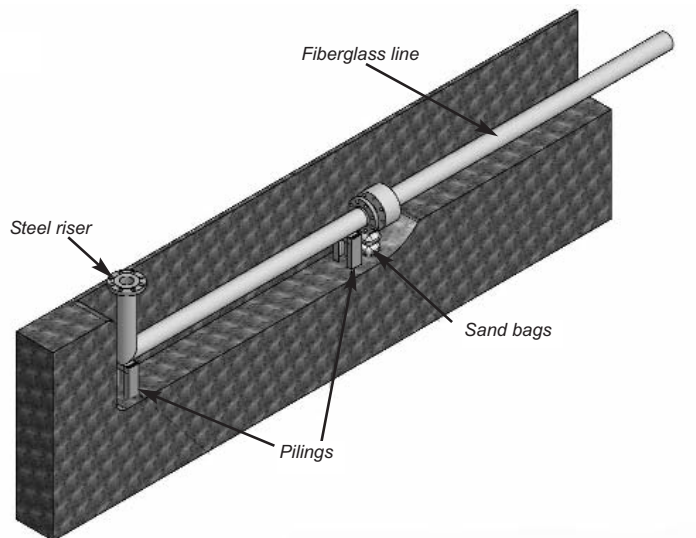

4. If pipe is not sitting on the bottom of the trench, sand should be put in the ditch and tamped to where Fiberglass line is the same elevation as the Steel Flange and there are no voids underneath the Fiberglass Pipe. Space sandbag underneath pipe no further than twelve (12) inch span between bags.

**TABLE ONE** >

Pipe Size	Torque Range ft-lbs (Kg-M)
<b>2 SP8</b>	100-150 (14-21)
<b>2½ SP8</b>	150-200 (21-28)
<b>3 SP8</b>	175-275 (24-38)
<b>4 SP8</b>	200-350 (28-48)
<b>6<sup>5</sup>/<sub>8</sub> SP8</b>	350-500 (48-69)
<b>7 SP8/7 SP8-HP</b>	350-500 (48-69)
<b>8 SP8/8 SP8-HP</b>	600-750 (83-104)

**TABLE TWO** >

Pipe Size	Torque Range ft-lbs (Kg-M)
<b>1½ SP</b>	50-100 (7-14)
<b>2 SP</b>	75-125 (11-17)
<b>2½ SP</b>	100-150 (14-21)
<b>3 SP</b>	175-250 (24-35)
<b>4 SP/SPH</b>	225-435 (31-60)
<b>5 SP</b>	235-465 (32-64)
<b>6 SP</b>	250-500 (35-69)
<b>6 SPH/6 SPH-HP</b>	300-575 (42-79)
<b>7¾ SPH</b>	500-800 (69-112)
<b>8 SPH/8 SPH-HP</b>	500-900 (69-125)
<b>10 SPH</b>	750-1200 (105-168)

**TABLE THREE** >

Pipe Size	Cutoff Amount
<b>2 SP8</b>	4 THDS
<b>2½ SP8</b>	5 THDS
<b>3 SP8</b>	6 THDS
<b>4 SP8</b>	7 THDS
<b>6<sup>5</sup>/<sub>8</sub> SP8</b>	6 THDS
<b>7 SP8</b>	7 THDS
<b>8 SP8</b>	11 THDS

Each joint should be checked with a known torque condition to assure that proper make-up torque has been achieved. High pressure products should be made to the high end of the range given and low pressure products should be made to the low end of the range given.

The torque values shown in Tables One and Two are for 70°F. Cooler installation temperatures require more torque and hotter temperatures require less. Use the factors in Table Four for the installation temperature(s) encountered. Note that these are for the temperature of the pipe at the end connectors, which may be higher or lower than the air temperature due to heating from the sun.

**TABLE FOUR** >

Temperature	Torque Factor
<b>below 10°F</b>	consult factory
<b>20</b>	1.4
<b>30</b>	1.3
<b>40</b>	1.2
<b>50</b>	1.15
<b>60</b>	1.08
<b>70</b>	1.00
<b>80</b>	.95
<b>90</b>	.91
<b>100</b>	.88

**III. BOND ON PIN** >

1. Pipe should be cut straight within + 1/16". Use a wrap-a-round to mark pipe or use a saw guide to facilitate straight cuts.
2. Taper angle of spigot should be 1 3/4°. Check taper tool angle by tapering a pipe using factory bell as a check. When factory bell is pushed dry onto spigot, no side to side motion should be possible if taper angles of bell and spigot match. Every taper should be checked in this manner.
3. Taper length should be such that when the fitting to be bonded is pushed dry onto the spigot, the end of the spigot should reach within 3/16" of the bottom of the bell.
4. Make sure bell and spigot are clean. (Bell may be cleaned and renewed by lightly sanding and wiping away dust particles.) Do not touch these surfaces with bare hands after cleaning. Mix adhesive according to manufacturer's instructions and apply thin coat of adhesive to both bell and spigot. Align bell and spigot and push together, with a turning motion, with enough force to lock the two parts together. If necessary, parts may be locked together by placing a 2" x 4" board flat across the end of the pin and tapping lightly with a hammer. Smooth out or remove excess resin inside the pipe. Do not disturb until adhesive has hardened. When temperatures are under 70°F the use of heat packs or other means of applying external heat is recommended. In all cases refer to adhesive literature.

**IV. PRESSURE >  
TESTING**

1. Hydrostatic testing can be potentially dangerous. Adequate safety precautions should always be taken to prevent damage or injury during testing.
2. Testing with air or gas is not recommended because of the potential danger of compressed gas. If a gas is used to test the pipe, the test should be carried out only after the pipe is completely buried. *See section on backfilling prior to starting any burial of pipe. **Air or nitrogen may be used, but the use of helium is strictly prohibited.***
3. An initial open ditch test should be performed prior to backfilling. This test requires covering of the pipe to the top of the ditch only in the area of 45 and 90 ells and tees for a distance of 20 feet in all directions from the fittings. The fittings should be left uncovered for inspection. Covering the rest of the pipe is not required, although plugs of backfill should be applied along bends and may be applied at intervals along the pipe for added restraint if desired. Leave all connections open for inspection. If this test is not performed, Centron will not be responsible for any costs involved in finding or repairing a leak in the line after the line has been backfilled.
4. When filling the line with water, a soft pig should be run ahead of the water to remove the air in the line.
5. The rate of pressurization of the line should not exceed 200 psi per minute.
6. During the open ditch test, the line may be pressurized to a pressure not to exceed the pipe's static pressure rating for a duration of not more than four (4) hours. During this test the line should be visually checked and monitored with a pressure gage or chart recorder.
7. Upon initial pressurization of the line some changes in gage pressure may be expected from air trapped in the line, and until temperature stabilization occurs. During the open ditch test, the line must be carefully monitored to prevent pressure increases during summer heating. Measures must also be taken in cold weather to prevent freezing of the test water.
8. After satisfactory completion of the open ditch test the line should be backfilled as soon as possible.
9. It is recommended that no more than 5000 feet of line be installed before an initial open ditch test is performed to verify the integrity of the installation. After completing the test, this section of line should be backfilled before installing and testing the next increment of pipe in the same installation. Release pressure prior to backfill.
10. A final test, after line has been completely backfilled, should be carried out as required by the customer or local regulatory requirements. Maximum recommended test pressure is 100% of the static pressure rating of the pipe. However, it is allowable at final test to pressure the line up to 125% of the static pressure rating of the pipe if necessary to meet licensing requirements. If testing above static pressure, contact distributor or manufacturer. Maximum allowable test duration is 24 hours.

**V. BACKFILLING >**

1. After testing has been completed, ditch should be backfilled as soon as possible to eliminate possible damage to the line from falling rock, flooding, etc.
2. The first six inches (minimum) of backfill above the top of the pipe should be good soil, free of sharp or large rocks and frozen clods of dirt. This cover of good soil provides even support for the pipe and protects it from damage as the rest of the ditch is backfilled with some times less desirable material. The use of equipment such as Pipeline Padder should be considered for long lines in rocky areas where the cost of hauling select backfill may exceed the cost of the padder.

*Centron® fiberglass tubing has given years of trouble free service in many demanding applications. Proper handling of the tubing before installation, proper selection of installation tools and a well-design compatible with Centron tubing will insure long service. The following is a general guide that reflects the experiences of successful well completions using Centron tubing. As it is impossible to cover all the variables encountered in the field, please feel free to consult with Centron International Inc.'s engineering department on any Centron tubing installation(s).*

### I. HANDLING >

Centron tubing is a strong, durable product but may be damaged by impact from a sharp object. This can cause localized delamination and render the tubing unusable. Care must be taken to prevent such damage at the yard, when unloading and handling at the well site. Tubing should be supported in at least four equally spaced points along the joint length and stacked using wooden stripping between layers, with pins/boxes staggered for even spacing, on a level surface.

### II. WELL DESIGN >

Good well design is essential to the successful use of Centron tubing. The maximum operating conditions (tension, pressure and temperature) must never be exceeded or permanent, irreversible damage may occur that decreases the life expectancy of the tubing. Centron tubing can be used with confidence when the following basic guidelines are observed:

1. Packer and downhole tool selection is important for the successful use of Centron tubing. Permanent or retrievable packers with “on/off” tools are preferred. These, unlike simple tension set retrievable packers, hold pressure from both sides and do not subject the tubing string to additional tension when pressure testing the annulus or when the well goes on vacuum. Packers designed for set/release via pick-up/set-down and rotation must not require torque that exceeds the made-up torque of the tubing joints.
2. Landing in the well head is generally done on stainless steel subs but may be done on Centron coupled fiberglass landing subs. Centron tubing must be used in tension and tension can only be applied to the tubing string using stainless steel or Centron coupled landing subs.
3. Pumping wells using sucker rods or electric submersible pumps (ESP) require some special considerations. Sucker rods must use polished couplings without sharp edges. Plastic coated rods are preferred. Deviated holes require plastic or wheeled rod guides. An anchor should be used in all pumping wells. If the tubing carries the weight of an ESP and its cable, some form of torque arrest may be required; either a mechanical torque arm on the pump or an electronic “soft start” motor starter.
4. Conventional tools may be run through fiberglass tubing. Swabs, blanking plugs, etc. may be run on properly lubricated sand, slick and electric lines. Lines must be run slowly in deviated holes to avoid “burn through” at contact points. Never attempt to “drag” stuck tools up fiberglass tubing as gouging will adversely affect the corrosion resistance and life of the tubing. If tools get stuck, it is usually more economical to cut or shoot off the line or/and the tubing and make the trip out rather than damage the tubing string.

### III. END >

#### CONNECTOR SELECTION

Centron tubing is available with our proprietary 4 round, O-ring connection or API standard 8rd EUE long form connections per API 5B, Table 14 (2 thru 4 inch) and Table 7 (6 thru 8 inch). Either connector is available with Centron's patented PeNG (non galling) female thread configuration. Our 4-round, O-ring threaded connection features larger, more rugged threads that are less susceptible to stab damage. The O-ring assures a seal under less than optimal make-up conditions and keeps the thread dope where it belongs—on the threads, not in the equipment or formation.

## IV. INSTALLATION &gt;

Centron tubing is run using conventional slips, elevators and pipe wrenches. The elevators should be the “slip” type and the tongs capable of low (<500 ft-lb) torque operation. Tongs and wrenches must be used only on the upsets, never on the barrel of the tubing. A weight indicator should be used at all times.

1. Packer or downhole steel tool connections should be made “cheater” tight to prevent “backing-off”. For fiberglass to steel connections use only fiberglass pins in steel boxes and make-up to maximum torque/position as described below.
2. Tailing the tubing from the rack to the well is done conventionally. Care must be taken to prevent damage to the pin end. Leave the thread protectors on the tubing until ready for make-up.

## A. DH (4 ROUND) CONNECTION

1. As each joint is handled it should be checked visually for shipping and/or handling damage. Shallow scratches and abrasions are generally insignificant but if the tubing has cuts into the laminate, bruises, or fractures it should be set aside for disposition.
2. After removal of end protectors, check box and pin threads for damage.
3. Check box and pin for contamination. Remove any contamination by wiping with clean cloths or paper towels. Use a fine wire brush for the removal of ice or dried, hard soil contamination. Be sure that the O-ring groove is clear of debris.
4. Application of Lubricant/Sealant
  - 4.1 For standard make-up of anhydride-cured tubing, apply a light, even coat of thread dope to the pin threads only. **Do not** allow any dope in the O-ring groove. A light coat of thread dope will affect a seal at the threads.
  - 4.2 The combination of Teflon® tape and thread dope is highly recommended for all tubing as it provides optimum sealing capability for Centron tubing connections and maximizes make and break capability for tripping the string. This combination must be used on all Centron amine-cured tubing. Following is the recommended procedure for using Teflon tape and thread dope:

Using 1” wide Teflon tape and starting from the small end of the threads, wrap the threads with the tape, advancing one thread pitch per revolution in a clockwise direction when facing pin end of the pipe. Apply a very light even coat of thread dope over the tape wrapped threads. Do not allow any tape or dope in the O-ring groove.
  - 4.3 Apply a light coat of seal lubricant to the O-ring groove.
  - 4.4 Install O-ring into the groove on the pin. Be careful not to damage the O-ring. Apply seal lubricant to the O-ring.
5. Stab the connection by hand, being careful to center the box and pin so that the O-ring or threads are not damaged upon initial engagement. **Proper alignment of the two joints during complete make-up is critical.** After proper visual alignment, make-up the connection by hand as far as possible. Rotation should be very smooth if proper alignment is maintained. After hand tight make-up, apply wrenches and make-up to position as follows: At **minimum make-up position**, the box edge to pin shoulder distance (standoff) must be no more than .25 in. (6.3 mm). At **maximum make-up position**, assembly must always stop before the box edge contacts the pin shoulder. **Do**

***not shoulder out the connection.*** Use torque values in Table One as a reference to monitor make-up.

6. Assemble connections to maximum make-up position as long as maximum reference torque is not exceeded. If a connection does not make-up to the .25 in. (6.3 mm) maximum standoff distance at maximum reference torque it should be disassembled, cleaned, and examined for contamination or galling of the threads. If no problem is found repeat the make-up procedure and if the problem persists set the joint aside for disposition.
7. Wrenches may be used only on the last 3 inches of the box and only on the upset area of the pin. Do not use wrenches on the body of the pipe. Select wrenches that fit well and maximize contact area with the pipe.
8. Some O-ring compounds lose elasticity at low (<10 °F) temperatures and may not seal. Before installing at low temperature, reference the cold weather installation section or contact Centron International, Inc.

#### **B. DH8 (8RD EUE) CONNECTION**

1. As each joint is handled it should be checked visually for shipping and/or handling damage. Shallow scratches and abrasions are generally insignificant, but if the tubing has cuts into the laminate, bruises, or fractures it should be set aside for disposition.
2. After removal of end protectors check box and pin threads for damage and/or contamination. Remove any contamination by wiping with clean cloths or paper towels. It is extremely important that all threads are clean. Use a fine wire brush for removal of ice or dried, hard soil.
3. In making connections to steel use only fiberglass pins in steel boxes. Fiberglass pins are of the long thread form and must be cut off by the amount shown in Table Two before make-up into short thread boxes. After this is accomplished clean threads, apply thread dope to both pin and box threads and make-up to torque shown in Table Three.
4. For fiberglass to fiberglass connections, when Teflon tape is required, use 1" wide Teflon tape. Starting from the big end of the threads, wrap the threads with the tape advancing 1/2" per revolution in a clockwise direction when facing the pin end of the pipe. Dwell 1 revolution at the small end, then back to the big end with the 1/2" overlap.

Apply a light, uniform coat of thread dope to the tape and to the box threads.

5. In making the connection, stab the connection by hand, being careful to center the box and pin so that threads are not damaged upon initial engagement. Alignment of the two joints is very important during complete make-up. After initial alignment and stabbing, make-up the joint by hand as far as possible. Rotation should be very smooth if proper alignment is maintained. After hand-tight make-up, apply wrenches and make-up to torque values shown in Table Three. **Caution: Do not over torque.** As a visual check during make-up to torque, the box edge should range from allowing the last two (2) pin

TABLE ONE >

Tubing Size	Torque Range (ft. - lbs.) (Kg - M)
1½	50-100 (17-14)
2%	75-125 (11-17)
2%	100-150 (14-21)
3½	175-250 (24-25)
4½	225-435 (31-60)
5, 5½	235-465 (32-64)
7	300-575 (42-79)
8%	500-900 (69-125)
10%	750-1200 (105-168)

TABLE TWO >

Tubing Size	Cutoff Amount
2% DH8	4 THREADS
2% DH8	5 THREADS
3% DH8	6 THREADS
4% DH8	7 THREADS

TABLE THREE >

Tubing Size	Torque Range (ft. - lbs.) (Kg - M)
2% DH8	100-150 (14-20)
2% DH8	150-200 (21-28)
3% DH8	175-275 (24-38)
4% DH8	200-350 (28-48)
6% DH8	300-575 (42-79)
7 DH8	300-575 (42-79)
9% DH8	500-900 (9-125)

V. COMPLETION >

threads to show to stopping flush with the last pin thread. ***Do not make-up past the flush position regardless of torque.***

Spacing out and landing the tubing properly is very important to the life cycle of the tubing. Well use and conditions will dictate how much landing tension is required. Refer to stretch tables for stretch data and compare these values to weight indicator values to assure that the entire string is in tension.

Backside fluid may be oil, diesel, inhibited brine, or properly treated fresh water. Fresh water must be free of any biological material and should be pH buffered and oxygen scavenged with sulfide or sulfite salt(s). High ph (>8) primary or secondary amine type inhibitors should not be used with anhydride cured epoxy tubing.

## VI. TRIP OUT

&gt;

Calculate string “live weight” in well (approximately half the string weight in air if the annular tubing fluid level is full). Swab and/or fill tubing or annulus to equalize fluid levels inside and out. Pick up string weight and remove landing equipment. Work through release sequence for the packer or on-off tool involved. If tool fails to release, lower string weight, up to 2000 pounds, and work through release sequence again. Several cycles of this strategy may be required if tubing has been in service a long time due to sedimentation in the annulus above the packer. Never exceed the tubing’s tensile rating during attempts to unlatch. If release is impossible it is usually more economical to shoot or mill off the tubing in the joint above the packer/anchor than it is to simply part the string with tension and fish from there. Parting the string with tension effectively destroys the properties of the whole tubing string. Fishing operations can be easily done with either a spear, overshot or combination tool. Fiberglass is also easily milled up.

Tubing may be pulled in doubles in sizes 2<sup>7</sup>/<sub>8</sub> and larger. Pin thread protectors must be used if tubing is left standing and proper tie-back is required. Tail-out, pin thread protectors, and wooden stripping should be used if tubing is laid down.

To reinstall, both threads should be thoroughly cleaned using kerosene or other distillate solvent and inspected. Damaged joints should be set aside and replaced. All O-rings should be inspected and any flattened or damaged O-rings replaced. It is good practice to reverse the order of installation of used tubing if the order of the original installation is known.

Nominal Size Inches (mm)	THREAD LUBRICANT/SEALANT			1" TFE TAPE REQUIREMENTS	
	LBS/ Joint	JTS 4 LB Pail 1.8 kg	JTS 9 LB Pail 4.1 kg	Joints/Roll	
		1296" roll	520" roll		
<b>1½ (40)</b>	0.011	360	810	12.5	5.0
<b>2 (50)</b>	0.013	300	690	10.0	4.0
<b>2½ (65)</b>	0.016	250	560	8.2	3.3
<b>3 (75)</b>	0.019	210	470	7.0	2.8
<b>4 (100)</b>	0.024	165	375	5.7	2.3
<b>5½ (140)</b>	0.030	135	300	4.7	1.9
<b>6 SP (150)</b>	0.036	110	250	3.7	1.5
<b>6 SPH (150)</b>	0.055	70	160	3.0	1.2
<b>7¼</b>					
<b>8 SPH (200)</b>	0.095	42	95	2.5	1.0
<b>10 SPH (250)</b>	0.110	36	82	2.0	NA

The above charts describe the thread lubricant/sealant requirements based on using "Lubon 404", or TF 15 and the TFE Tape usage when taping is required.

